



# Data Sheet

## VI-200, VE-200

### DC-DC Converters

#### 50 to 200 Watts



#### Features

- RoHS compliant (VE-200)
- Up to 50 W/in<sup>3</sup>
- cULus, cTUVus
- Up to 90% efficiency
- Size: 4.6" x 2.4" x 0.5" (116,8 x 61,0 x 12,7mm)
- Remote sense and current limit
- OVP, thermal shutdown
- Logic disable
- Wide range output adjust
- Compatible power booster modules
- ZCS power architecture
- Low noise FM control
- CE Marked
- Isolated output

#### Product Highlights

The VI-200 family, with over 14 million units shipped, is Vicor's broad series of "zero-current-switching" component-level DC-DC converters.

Operating at frequencies up to 2 MHz, VI-200 family converters offer exceptional power density, efficiency, noise performance, reliability and ease of use. Booster modules (VI-Bxx) provide a simple, cost-effective, off-the-shelf solution for higher power output requirements. One or more boosters may be used to create synchronous arrays capable of supplying several kilowatts of output power.

The flexibility of Vicor's power components is also available in half-size, half-power VI-J00 MiniMods.

#### Part Numbering

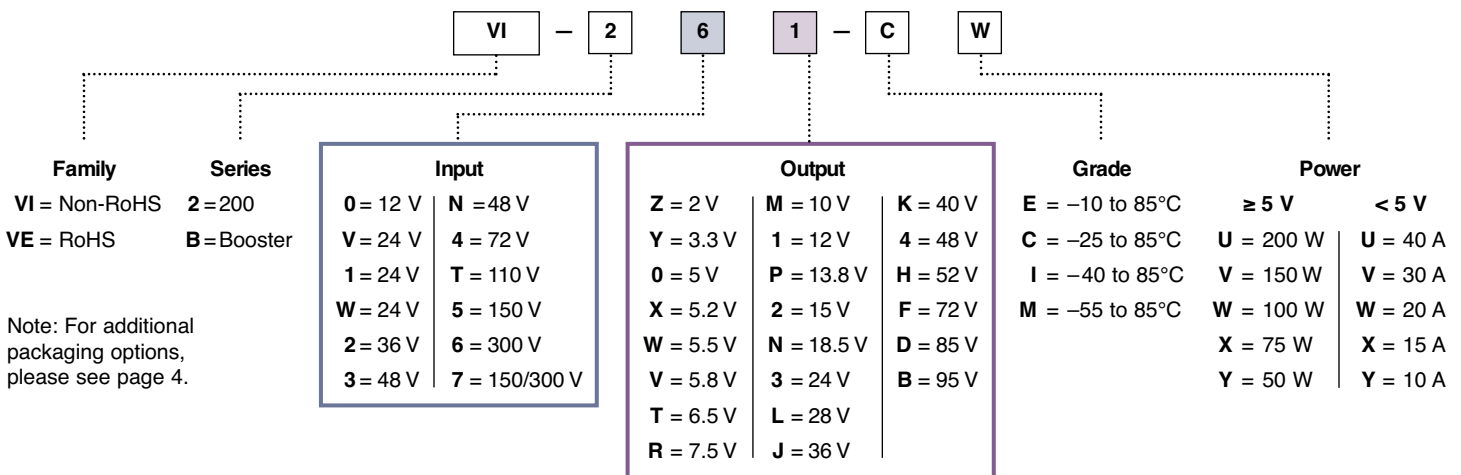

#### Maximum Power Available for VI-2xx-xx<sup>[a]</sup>

Input				Output																					
Voltage Nom. (Range)	Low Line 75% Max Power	Transient <sup>[b]</sup>	Vin Designators	Vout Designators																					
				2	3.3	5	5.2	5.5	5.8	6.5	7.5	10	12	13.8	15	18.5	24	28	36	40	48	52	72	85	95
				Z	Y	0	X	W	V	T	R	M	1	P	2	N	3	L	J	K	4	H	F	D	B
12 (10-20)	n/a	22	0	X	X	X	X	X	X	X	X	X	X	X	X	X	X	X	X	X	X	X	X	X	X
24 (10-36)	n/a	n/a	V	--	X	Y	Y	Y	Y	Y	X	X	X	X	X	X	X	X	X	X	X	--	--	--	--
24 (21-32)	18	36	1	U	U	U	U	U	U	V	V	U	U	U	U	U	U	U	U	U	U	U	U	U	U
24 (18-36)	n/a	n/a	W	V	V	V	V	V	V	W	W	V	V	V	V	V	V	V	V	V	V	V	V	V	V
36 (21-56)	18	60	2	W	V	W	W	W	W	W	W	W	W	W	W	W	W	W	W	W	W	--	--	--	--
48 (42-60)	36	72	3	U	U	U	U	U	U	U	U	U	U	U	U	U	U	U	U	U	U	U	U	U	U
48 (36-76)	n/a	n/a	N	V	U	U	U	U	U	U	U	U	U	U	U	U	U	U	U	U	U	U	U	U	U
72 (55-100)	45	110	4	U	U	U	U	U	U	V	V	U	U	U	U	U	U	U	U	U	U	U	U	U	U
110 (66-160)	n/a	n/a	T	V	V	V	V	V	V	W	W	V	V	V	V	V	V	V	V	V	V	V	V	--	--
150 (100-200)	85	215	5	U	U	V	V	V	V	V	V	U	U	U	U	U	U	U	U	U	U	U	U	U	U
150 (100-375)	90	n/a	7	W	W	Y	Y	Y	Y	W	W	W	W	W	W	W	W	W	W	W	W	W	--	--	--
300 (200-400)	170	425	6	U	U	U	U	U	U	V	V	U	U	U	U	U	U	U	U	U	U	U	U	U	U

<sup>[a]</sup> For additional output power, "booster" modules are available. (VI-Bxx-xx)

<sup>[b]</sup> Transient voltage for 1 second.

## CONVERTER SPECIFICATIONS

(typical at  $T_{BP} = 25^{\circ}\text{C}$ , nominal line and 75% load, unless otherwise specified)

### INPUT SPECIFICATIONS

Parameter	VI-200 E-Grade			VI-200 C-, I-, M-Grade			Units	Test Conditions
	Min	Typ	Max	Min	Typ	Max		
Inrush charge		$120 \times 10^{-6}$			$120 \times 10^{-6}$	$200 \times 10^{-6}$	Coulombs	Nominal line
Input reflected ripple current – pp		10%			10%		$I_{IN}$	Nominal line, full load
Input ripple rejection		$25 + 20 \text{Log} \left( \frac{V_{in}}{V_{out}} \right)$		$30 + 20 \text{Log} \left( \frac{V_{in}}{V_{out}} \right)$			dB	120 Hz, nominal line
				$20 + 20 \text{Log} \left( \frac{V_{in}}{V_{out}} \right)$				
No load power dissipation		1.35	2		1.35	2	Watts	

### OUTPUT CHARACTERISTICS

Parameter	VI-200 E-Grade			VI-200 C-, I-, M-Grade			Units	Test Conditions	
	Min	Typ	Max	Min	Typ	Max			
Setpoint accuracy		1%	2%		0.5%	1%	$V_{NOM}$		
Load/line regulation			0.5%		0.05%	0.2%	$V_{NOM}$	LL to HL, 10% to Full Load	
Load/line regulation			1%		0.2%	0.5%	$V_{NOM}$	LL to HL, No Load to 10%	
Output temperature drift		0.02			0.01	0.02	% / $^{\circ}\text{C}$	Over rated temp.	
Long term drift		0.02			0.02		%/1K hours		
Output ripple – pp:			150		60	100	mV	20 MHz bandwidth	
			2 V, 3.3 V					$V_{NOM}$	20 MHz bandwidth
			5 V					$V_{NOM}$	20 MHz bandwidth
			3%		0.75%	1.5%	$V_{NOM}$	20 MHz bandwidth	
10 – 48 V							$V_{NOM}$	20 MHz bandwidth	
Trim range <sup>[a]</sup>	50%		110%	50%		110%	$V_{NOM}$		
Total remote sense compensation	0.5			0.5			Volts	0.25 V max. neg. leg	
OVP set point		125% <sup>[b]</sup>		115%	125% <sup>[b]</sup>	135%	$V_{NOM}$	Recycle power	
Current limit	105%		135%	105%		125%	$I_{NOM}$	Automatic restart	
Short circuit current <sup>[c]</sup>	20%		140%	20%		130%	$I_{NOM}$		

<sup>[a]</sup> 10 V, 12 V, 15 V outputs, or “V” input range have standard trim range  $\pm 10\%$ . Consult factory for wider trim range.

3.3 V output trim range 2.20 to 3.63 V, 95 V output  $-50 + 0\%$  trim range.

<sup>[b]</sup> 131% nominal for booster modules.

<sup>[c]</sup> Output voltages of 3.3 V or 5 V incorporate foldback current limiting; For output voltages from 5.2 V to 7.5 V consult factory; All other outputs provide constant current limiting.

### CONTROL PIN SPECIFICATIONS

Parameter	VI-200 E-Grade			VI-200 C-, I-, M-Grade			Units	Test Conditions
	Min	Typ	Max	Min	Typ	Max		
Gate out impedance		50			50		Ohms	
Gate in impedance		1000			1000		Ohms	
Gate in open circuit voltage		6			6		Volts	Use open collector
Gate in low threshold	0.65			0.65			Volts	
Gate in low current			6			6	mA	
Power sharing accuracy	0.95		1.05	0.95		1.05		

## CONVERTER SPECIFICATIONS (cont.)

### ■ DIELECTRIC WITHSTAND CHARACTERISTICS

Parameter	VI-200 E-Grade			VI-200 C-, I-, M-Grade			Units	Test Conditions
	Min	Typ	Max	Min	Typ	Max		
Input to output	3,000			3,000			V <sub>RMS</sub>	Baseplate earthed
Output to baseplate	500			500			V <sub>RMS</sub>	
Input to baseplate	1,500			1,500			V <sub>RMS</sub>	

### ■ THERMAL CHARACTERISTICS

Parameter	VI-200 E-Grade			VI-200 C-, I-, M-Grade			Units	Test Conditions
	Min	Typ	Max	Min	Typ	Max		
Efficiency		78 – 88%			80 – 90%			
Baseplate to sink thermal impedance		0.07			0.07		°C/Watt	With Vicor P/N 20266
Thermal shutdown <sup>[d]</sup> (Drivers only)	90	95	105	90	95	105	°C	Cool and recycle power to restart

<sup>[d]</sup> No overtemp protection in booster modules.

### ■ MECHANICAL SPECIFICATIONS

Parameter	VI-200 E-, C-Grade			VI-200 I-, M-Grade			Units	Test Conditions
	Min	Typ	Max	Min	Typ	Max		
Weight	5.7 (160.2)	6.3 (178)	6.9 (195.8)	6.6 (187.2)	7.3 (208)	8.1 (228.8)	Ounces (Grams)	

### ■ PRODUCT GRADE TEMPERATURES

Parameter	Storage	Operating	Units	Notes
E	-20 to +100	-10 to + 85	°C	Overtemperature shutdown 95°C typical (recycle power to restart)
C	-40 to +100	-25 to + 85	°C	
I	-55 to +100	-40 to + 85	°C	
M	-65 to +100	-55 to + 85	°C	

# MECHANICAL DRAWING

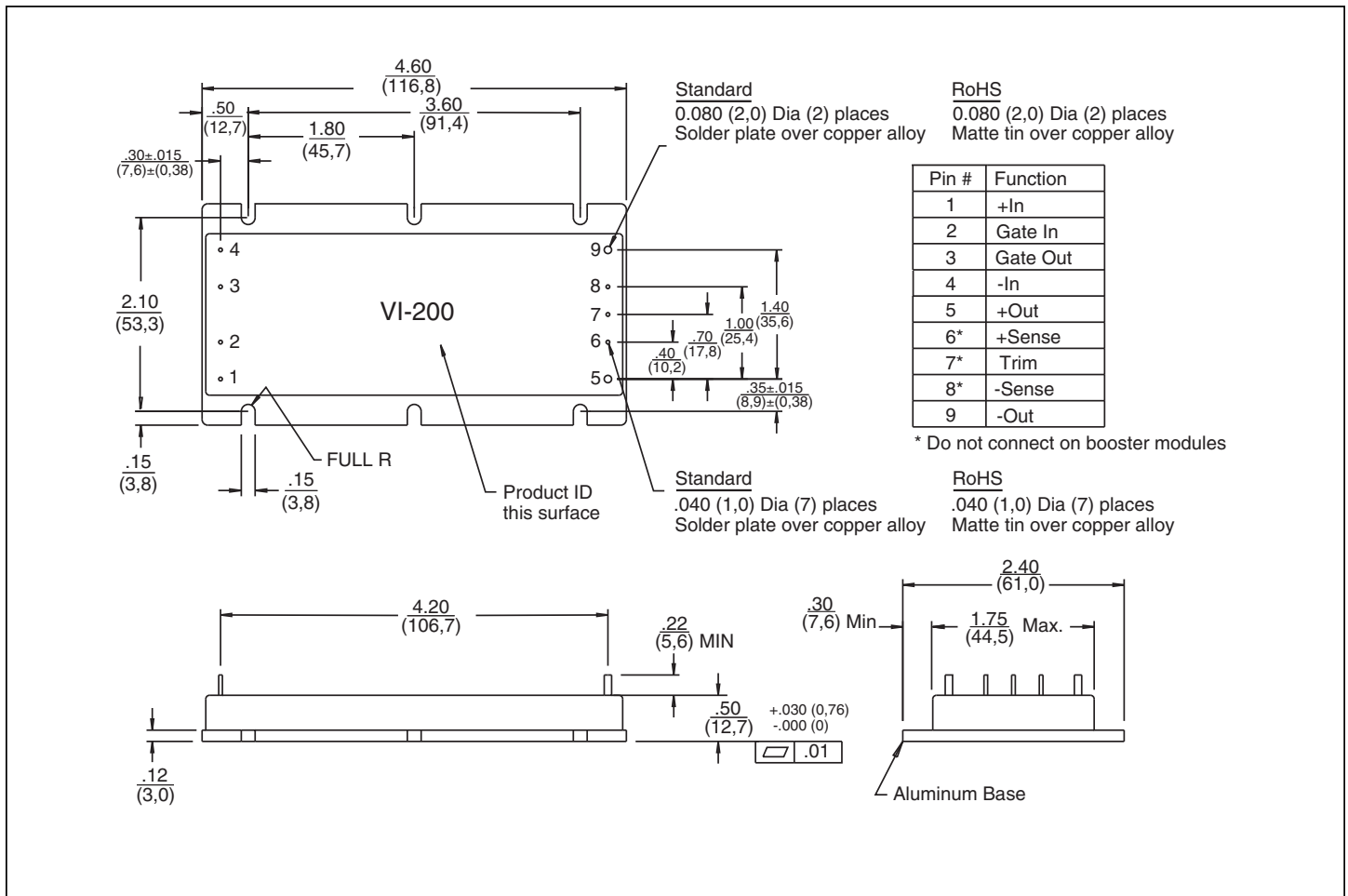

## PACKAGING OPTIONS

### SlimMod Flangeless package



4.60"L x 1.80"W x 0.50"H  
(116,8 x 45,7 x 12,7 mm)

To order the SlimMod configuration add the suffix "-S" to the standard module part number.

Qty (2) grounding clips are included with each SlimMod  
P/N 32187

### FinMod Flangeless package with integral heat sink



Longitudinal, 0.25" fins — add suffix "-F1"  
Longitudinal, 0.50" fins — add suffix "-F2"



Transverse, 0.25" fins — add suffix "-F3"  
Transverse, 0.50" fins — add suffix "-F4"

Available with longitudinal or transverse fins of 0.25" or 0.50" height. Add the appropriate suffix to the module part number.

Qty (4) grounding clips are included with each FinMod  
F1, F2 P/N 32185  
F3, F4 P/N 32186

### MegaMod Chassis mount alternatives, one, two, or three outputs: up to 600 W



1 up - 4.9" x 2.5" x 0.62" (124,4 x 63,5 x 15,7 mm)  
2 up - 4.9" x 4.9" x 0.62" (124,4 x 124,4 x 15,7 mm)  
3 up - 4.9" x 7.3" x 0.62" (124,4 x 185,4 x 15,7 mm)

### BusMod



4.60"L x 2.40"W x 1.08"H  
(116,8 x 61,0 x 27,4 mm)

To order the BusMod fully assembled, add suffix "-B1" to the standard module part number.

To order the BusMod separately:  
Full-sized BusMod — P/N 06322

## **Warranty**

Vicor products are guaranteed for two years from date of shipment against defects in material or workmanship when in normal use and service. This warranty does not extend to products subjected to misuse, accident, or improper application or maintenance. Vicor shall not be liable for collateral or consequential damage. This warranty is extended to the original purchaser only.

EXCEPT FOR THE FOREGOING EXPRESS WARRANTY, VICOR MAKES NO WARRANTY, EXPRESS OR IMPLIED, INCLUDING, BUT NOT LIMITED TO, THE WARRANTY OF MERCHANTABILITY OR FITNESS FOR A PARTICULAR PURPOSE.

Vicor will repair or replace defective products in accordance with its own best judgement. For service under this warranty, the buyer must contact Vicor to obtain a Return Material Authorization (RMA) number and shipping instructions. Products returned without prior authorization will be returned to the buyer. The buyer will pay all charges incurred in returning the product to the factory. Vicor will pay all reshipment charges if the product was defective within the terms of this warranty.

Information published by Vicor has been carefully checked and is believed to be accurate; however, no responsibility is assumed for inaccuracies. Vicor reserves the right to make changes to any products without further notice to improve reliability, function, or design. Vicor does not assume any liability arising out of the application or use of any product or circuit; neither does it convey any license under its patent rights nor the rights of others. Vicor general policy does not recommend the use of its components in life support applications wherein a failure or malfunction may directly threaten life or injury. Per Vicor Terms and Conditions of Sale, the user of Vicor components in life support applications assumes all risks of such use and indemnifies Vicor against all damages.

## **Vicor's comprehensive line of power solutions includes high density AC-DC and DC-DC modules and accessory components, fully configurable AC-DC and DC-DC power supplies, and complete custom power systems.**

Information furnished by Vicor is believed to be accurate and reliable. However, no responsibility is assumed by Vicor for its use. Vicor components are not designed to be used in applications, such as life support systems, wherein a failure or malfunction could result in injury or death. All sales are subject to Vicor's Terms and Conditions of Sale, which are available upon request.

**Specifications are subject to change without notice.**

## **Intellectual Property Notice**

Vicor and its subsidiaries own Intellectual Property (including issued U.S. and Foreign Patents and pending patent applications) relating to the products described in this data sheet. Interested parties should contact Vicor's Intellectual Property Department.

**Vicor Corporation**  
25 Frontage Road  
Andover, MA, USA 01810  
Tel: 800-735-6200  
Fax: 978-475-6715

### **email**

Customer Service: [custserv@vicorpower.com](mailto:custserv@vicorpower.com)  
Technical Support: [apps@vicorpower.com](mailto:apps@vicorpower.com)